

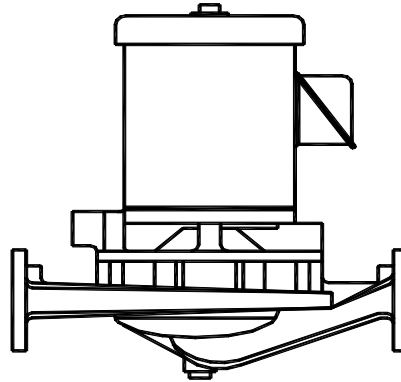

OPERATING AND MAINTENANCE INFORMATION FOR TV2g IN-LINE CENTRIFUGAL PUMP



INSTALLATION

LOCATION

The pump should be located as close to the liquid source as possible so that the suction line can be short and direct. It should be located in a clean, open area, where it is easily accessible for inspection, lubrication and repair. Pumps installed in dark, dirty areas or in cramped locations are often neglected which can result in premature failure of both the pump and driver.

Adequate provisions should be made for electrical wiring to the pump motor. A switch and overload protection should be installed near the pump unless it is impractical. The flexible electrical conduit should be connected to the motor in such a way as to preclude the possibility of moisture entering the conduit or the motor and causing short circuits.

MOUNTING

Thrush In-line pumps conserve floor space, simplify piping, and can be serviced without disconnecting piping. They are designed to be installed in either the vertical or horizontal position. The proper installation of these pumps is to install them as "a part of the piping". The pumps must be free to "travel" with the expansion and contraction of the piping. In-line installation eliminates the problems normally encountered in aligning piping to a base mounted unit. SUPPORT OF THE TV2g SERIES PUMPS SHOULD ALWAYS BE CONNECTED TO THE PIPING RATHER THAN TO THE PUMP CASING. (See Figure 2). The line-mounted feature eliminates the need for installing flexible pipe connectors at either the pump suction or discharge. Isolating valves should be installed at both the pump suction and discharge to permit servicing of the pump without draining the entire system. Make certain the space above the pump is sufficient to give clearance for lifting the pump assembly from the casing. Also, the space around the pump should be large enough for general accessibility and ventilation. The same criteria and formula for selecting piping supports are used with the additional consideration that the weight of the pump is concentrated at one point in the piping.

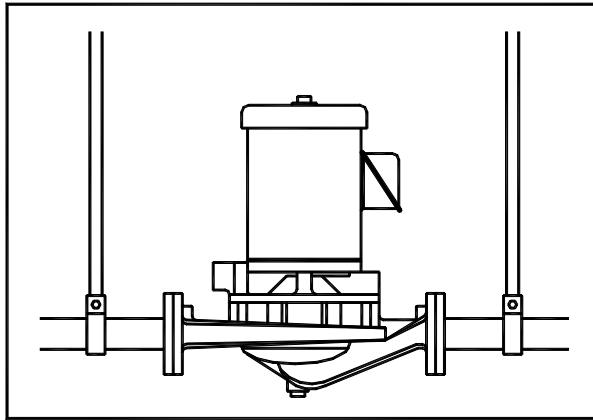

Figure 2: TYPICAL TV 2g MOUNTING

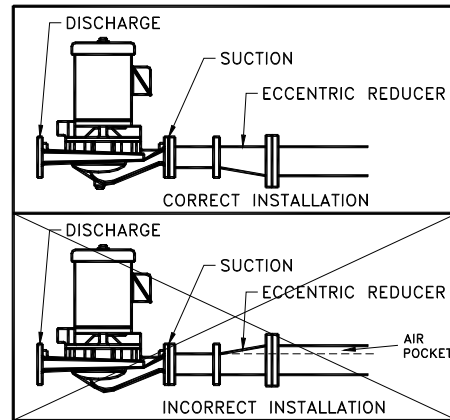

Figure 3: REDUCER TYPES

PIPING

The piping practices followed will directly affect the efficiency and power consumption of the pump. Pay particular attention to the seemingly insignificant details involved in piping for they make the difference between a good and bad installation. BOTH THE SUCTION AND THE DISCHARGE PIPING SHOULD BE INDEPENDENTLY SUPPORTED NEAR THE PUMP. LIBERAL USE OF PIPE HANGERS AND SUPPORT BLOCKS WILL PREVENT EXCESSIVE STRAIN ON THE PUMP CASING AND ON THE PIPE JOINTS. The suction diameter should be at least the same diameter as the suction nozzle on the pump and preferably larger. Use of a smaller diameter pipe will result in loss of head due to friction. All joints must be tight to maintain prime on the pump.

SUCTION PIPING

Long radius elbows should be used in place of standard elbows wherever possible because of their superior flow characteristics. Elbows should not be used at the suction nozzle, but if it is unavoidable, long radius elbows should be used. Elbows installed in any position at the suction nozzle have a tendency to distribute liquid unevenly in the impeller eye and may cause reduction in capacity, create an undesirable thrust condition, or create noisy operation. Eccentric reducers should be installed directly at the suction nozzle, with the taper at the bottom to prevent air pockets from forming. Straight taper reducers should never be used in a horizontal suction line because of the air pocket that is formed at the leg of the reducer and the pipe (Refer to Figure 3).

DISCHARGE PIPING

The discharge pipe diameter should be the same as, or larger than, the discharge nozzle diameter. The size of the discharge pipe to be used is dependent upon its application.

Long radius elbows should be used in the discharge piping as well as in the suction piping to prevent excessive head loss due to friction. Whenever possible, elbows should not be installed directly at the discharge nozzle as the turbulence created by the elbow will affect pressure gauge readings.

An increaser should be installed at the discharge nozzle if larger diameter discharge piping is used. Straight taper increasers and/or reducers are satisfactory in discharge applications.

PROPER PIPING ALIGNMENT IS ESSENTIAL BEFORE CONNECTION IS MADE. PIPING ALIGNMENT SHOULD NEVER BE ACHIEVED BY FORCE. THIS COULD PRODUCE STRAIN ON THE PIPING AND THE PUMP CASING. PROPER SUPPORTS SHOULD BE INSTALLED FOR THE PIPING TO KEEP ITS WEIGHT OFF THE PUMP CASING.

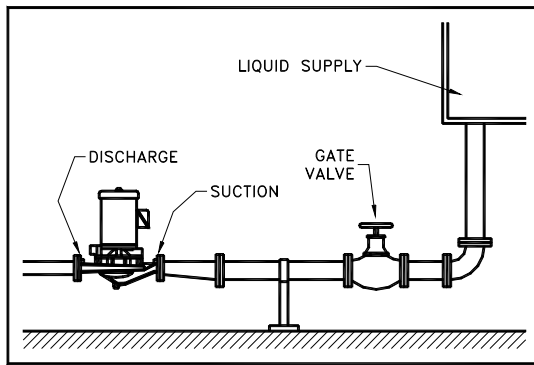

Figure 4: FLOODED SUCTION PRIMING

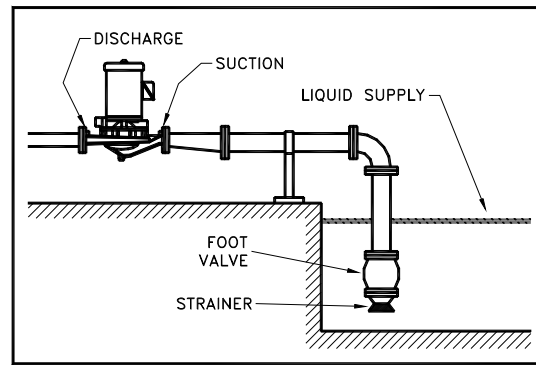

Figure 5: PRIMING WITH A FOOT VALVE

OPERATION

CAUTION: Centrifugal pumps should never be started or run dry. Operating a pump dry will cause scoring of the mechanical seals, resulting in premature seal failure. To prevent the pump from being run dry, it should be primed before starting. Failure to do so will void any warranties.

PRIMING THE PUMP

The pump will not operate satisfactorily until it is primed. All air must be expelled from the suction piping and pump casing and replaced by the liquid to be pumped. There are several methods of priming pumps. The one selected will depend on the specific requirements.

FLOODED SUCTION PRIMING

This method of priming a pump is relatively simple (See Figure 4). The liquid source is located above the pump and all that is necessary to prime the pump is to open the air vent valve or plug in the pump casing and to crack the isolating valve in the suction line. The suction line and pump should be filled slowly until a steady stream of liquid is observed flowing from the air vent. After the pump is operating, it is recommended that the air vent valve or plug be opened again to insure that all air has been expelled from the pump casing.

SUCTION LIFT

A foot valve should be used for priming on suction lift applications (See Figure 5). The foot valve located at the bottom end or foot of the suction piping functions as a check valve, which allows flow in one direction only, toward the pump. Otherwise, all the liquid may drain from the pump and suction piping back into the sump after shutdown.

Initial priming is accomplished by completely filling the suction piping and pump casing with the liquid to be pumped. This can be done by removing the air vent valve or plug at the top of the pump casing and inserting a pipe nipple in the orifice with an appropriate increaser to accommodate a hose connection. A priming line can also be inserted in the discharge piping between the check valve and the pump, or the priming can be done with a bucket and funnel. The important thing is to completely fill the suction pipe and pump casing with liquid.

When the pump is started, the vacuum created by pumping the priming fluid, combined with atmospheric pressure in the liquid well forces liquid into the suction piping, thus opening the valve and keeping it open until the pump is shut down. When the pump is shut down, the liquid being pumped reverses its flow causing the valve to close. The liquid is now trapped in the suction piping and pump casing, thus maintaining a prime on the pump.

VACUUM PRIMING

Vacuum priming consists of removing air from the pump casing and suction piping and drawing liquid into them by means of a vacuum-creating device. The types of vacuum equipment range from a simple hand pump to a complex central priming system. The specific priming requirements will govern what type of vacuum primer is used.

STARTING THE PUMP

The discharge-isolating valve should be partially closed when the pump is started in order to avoid possible water hammer and initial power draw. As soon as the pump is up to operating speed, the discharge-isolating valve should be opened to the desired position. The motor should turn clockwise when viewed from the motor end and counter-clockwise when viewed from the casing end.

MAINTENANCE

It is doubtful a Thrush pump will ever require complete disassembly. Generally, only certain components need be disassembled to accomplish inspection or repair.

DISASSEMBLY

Since the Thrush TV2g pump is a back pull out design, it is unnecessary to disconnect piping or casing for service. All service and maintenance can be performed by disconnecting the electric service and removing the bracket motor assembly from the casing.

1. Close suction and discharge valves.
2. Break electrical connections to prevent drive unit from being energized during disassembly.
3. Unscrew pipe plugs (31) from suction and discharge ends of casing (28) and bottom of casing (28) to drain pump.
4. Remove all relief, cooling, flushing or drain lines, if present, from the pump.
5. Disconnect wiring at the motor.
6. Remove capscrews (30) from bracket (15) and lift motor bracket assembly from casing (28). Remove casing gasket (27).
7. Unscrew impeller bolt (35) and remove impeller washer (34), taking care not to damage gaskets (33).
8. Slide impeller (37) and impeller key (14) from the shaft, again taking care not to damage sleeve gasket (23).
9. Remove impeller key (14).
10. Wear ring (39) is pressed into casing with an interference fit and must be removed with a puller if replacement is necessary. (The wear ring is an optional item on the pump.)
11. If replacing seal cartridge assembly (19, 20, 21 & 22), slide seal cartridge assembly off the shaft.

NOTE: If replacing the mechanical seal only (21 & 22), slide seal assembly off the shaft. Remove snap ring (20) at the spring end. Remove spring and seal head (22). The rubber in seal head (22) may be partially adhered to shaft sleeve (19). Remove seat and O-ring (21). The sleeve should be carefully cleaned to remove any residue in seal area and checked for abrasion and corrosion. The sleeve under the seal may be polished lightly to 32RMS finish before replacing seal assembly (21 & 22). DO NOT REUSE A PITTED SLEEVE.

CAUTION: The mechanical seal is a precision product and must be treated as such. During removal great care must be taken to avoid dropping any part of the seal. Take particular care not to scratch the lapped faces on the washer or the sealing seal. Do not put a seal back into service until the sealing faces of the washer and seat have been lapped or replaced.

12. The seal cavity of the bracket (15) should be cleaned of all residues. Make sure that the 1/32 inch radius in the seal seat cavity is not damaged during disassembly since a sharp edge can easily cut the O-ring during reassembly.
13. Unscrew capscrews (30) to remove bracket from motor.

REASSEMBLY

1. Mount bracket (15) by screwing capscrews (30) evenly into motor to assure proper alignment. Turn all capscrews in an even amount.
2. Thoroughly inspect the seal cavity in the bracket for burrs or nicks which could damage the seat of the seal. APPLY A FILM OF SOAP PASTE OR FLAX SOAP (DO NOT USE OIL OR GREASE) TO THE SEAT AND O-RING (21).

If replacing seal cartridge assembly, remove cardboard spacer and slide assembly (19, 20, 21 & 22) onto motor shaft (50).

If it is not possible to insert seal assembly with fingers, press into place with a piece of tubing with the end cut square and matching sleeve diameter. Tubing should be slightly larger than the diameter of the shaft. Spring tension will probably prevent the sleeve from remaining in position axially until the impeller is locked against it.

- 2A. When replacing a mechanical seal only (21 & 22) wipe the sealing faces of the seat and seal washer clean. Lubricate these surfaces and shaft sleeve (19) with a clean soap solution. Put seat and O-ring (21) on shaft sleeve (19), smooth side to pump end. Slide the entire rotating assembly onto the sleeve. Carbon in seal head must mate with seal seat. Replace snap ring (20). The shaft sleeve with the seal rotating assembly on it may now be replaced onto the motor shaft, and into the bracket. Spring tension will probably prevent the sleeve from remaining in position axially until the impeller is locked against it.
3. Press wear ring (39) into casing (28) if change is necessary. Ring should not be hammered into place. Use a press, or clamp the parts in a bench vise, using wooden blocks to protect the ring. It may be necessary to pin or dowel the ring after assembly if the casing has had the ring replaced before, since each reassembly can stretch or tear metal and thereby loosen the fit. If the facilities are available, it is good practice to take a very light finish cut or to ream the inside diameter of the casing ring after pressing to restore roundness. When the ring is pressed, it may be squeezed out of shape.
4. Carefully place sleeve gasket (23) on motor end of impeller. Assemble impeller key (14) and impeller (37) to shaft. Secure impeller with impeller washer gasket (33), impeller washer (34), impeller bolt gasket (36), and impeller bolt (35).
5. Replace casing gasket (27) on bracket (15). Slide entire motor bracket assembly into casing (28) being careful not to damage casing gasket (27). With assembly properly positioned in casing (28) replace capscrews (30). Turn all capscrews in and tighten evenly.

6. Install the three pipe plugs (31) in the pump casing.
7. Replace all relief, cooling, flushing or drain lines.
8. Read carefully the section of this manual title OPERATION.
9. Connect electricity to motor.
10. Open suction and discharge valves.
11. Loosen pipe plug (31) and vent seal chamber prior to starting.

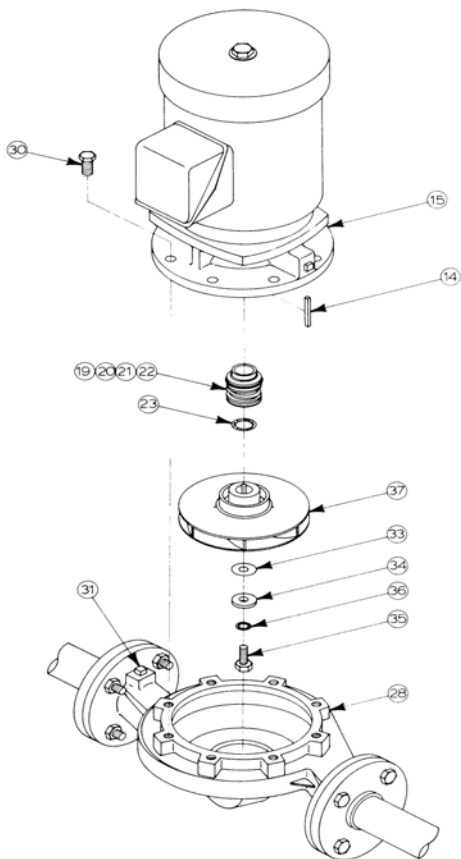

TV2g Parts List

- | | |
|-----|--------------------------------------|
| 14. | Impeller Key |
| 15. | Bracket |
| 16. | Spacer Ring (not shown) |
| 19. | } Cartridge |
| 20. | |
| 21. | |
| 22. | |
| 23. | Sleeve Gasket |
| 27. | Casing Gasket (not shown) |
| 28. | Casing |
| 29. | Pipe Plug |
| 30. | Cap Screw |
| 33. | Imp. Washer Gasket |
| 34. | Imp. Washer |
| 35. | Imp. Bolt |
| 36. | Imp. Bolt Gasket |
| 37. | Impeller |
| 39. | Suction Wear Ring (not shown) |
| 50. | Motor (not shown) |